



Montageanleitung

Installation instructions

Instructions de montage

Montagehandleiding

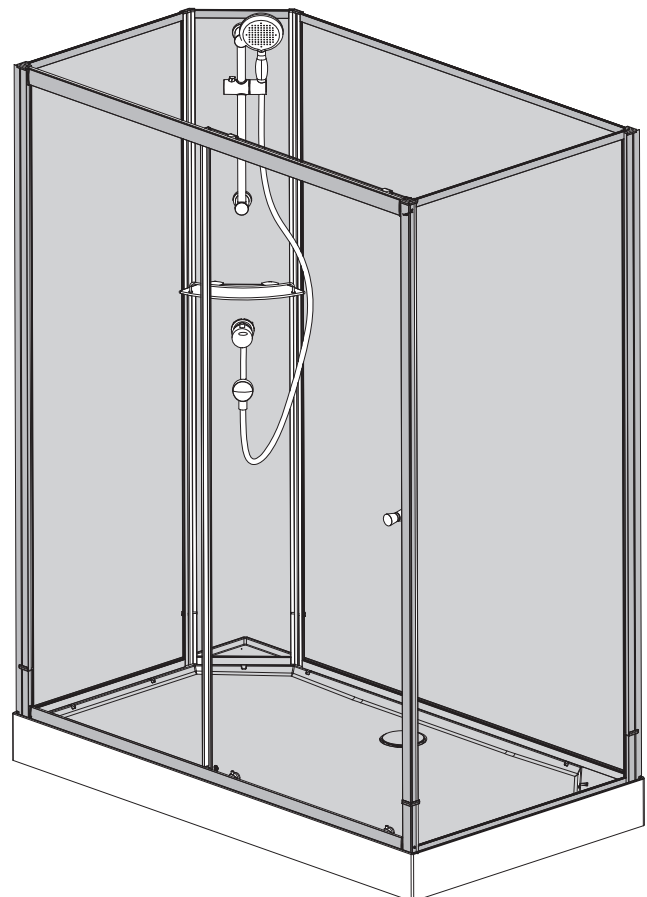
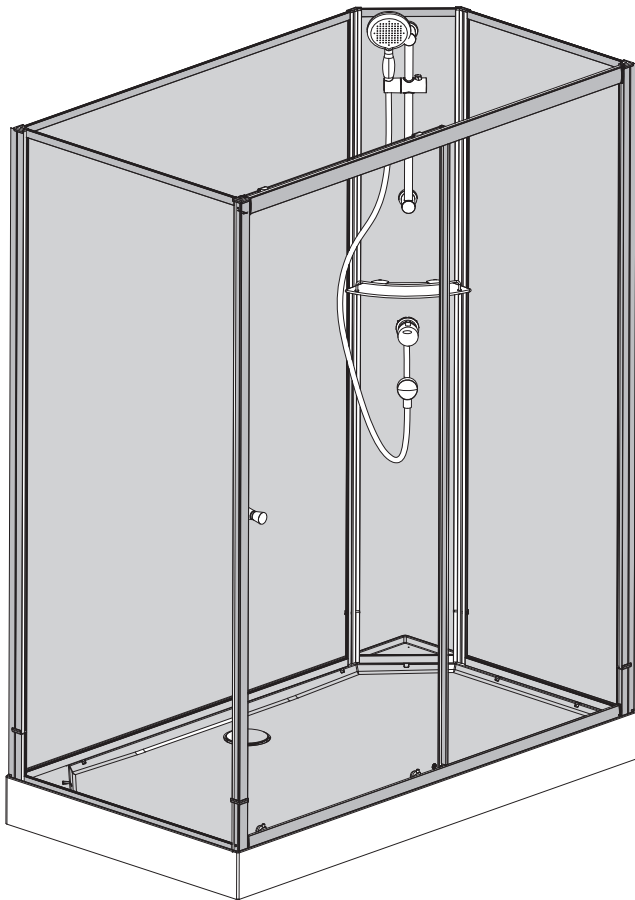



SICHERHEITSHINWEISE / SAFETY INSTRUCTIONS CONSEILS DE SÉCURITÉ / VEILIGHEIDSAANWIJZINGEN



de Glaskanten schützen

en Protect glass edges

fr Protégez les bords du verre

nl Glasranden beschermen



de Schutzbrille tragen

en Wear safety goggles

fr Portez des lunettes de protection

nl Veiligheidsbril dragen

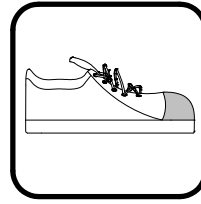

de Sicherheitsschuhe tragen

en Wear safety shoes

fr Portez des chaussures de sécurité

nl Veiligheidsschoenen dragen

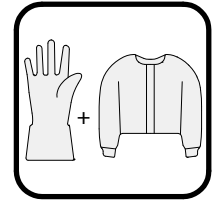

de Lange Handschuhe und langärmelige Kleidung tragen

en Wear long gloves and long-sleeved clothing

fr Portez des gants longs et des vêtements à manches longues

nl Draag lange handschoenen en kleding met lange mouwen

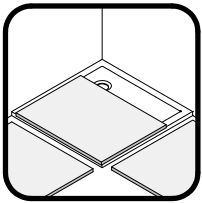

de Decken im Arbeitsbereich und dessen Umfeld auslegen

en Cover the shower tray and its area completely

fr Couvrez complètement le bac de douche et ses environs

nl Dekens op de douchebak en de omgeving leggen

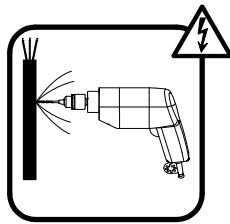

de Über die Lage der Stromleitung informieren

en Get information about the location of the power line

fr Informez-vous sur l'emplacement de la ligne électrique

nl Informeren over de locatie van de hoogspanningslijn

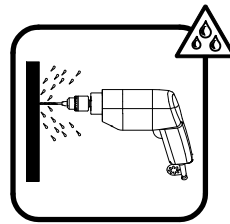

de Über die Lage der Wasserleitung informieren

en Get information about the location of the water pipe

fr Informez-vous sur l'emplacement de la ligne d'eau

nl Informeren over de locatie van de waterleiding



de Empfohlene Montage mit 2 Personen.

en Assembly recommended with 2 persons

fr Montage recommandé avec 2 personnes

nl Aanbevolen montage met 2 personen

HINWEIS / NOTE / NOTE / NOOT

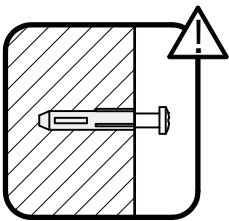

de Vor der Montage die Beschaffenheit des Mauerwerks überprüfen. Gegebenenfalls ist das im Lieferumfang enthaltene Befestigungsmaterial nicht für die Befestigung geeignet.

en Check the condition of the masonry before installation. If applicable, the fixing material included in the scope of delivery is not suitable for mounting.

fr Vérifiez l'état de la maçonnerie avant le montage. Le cas échéant, le matériel de fixation compris dans la livraison n'est pas adapté à la fixation.

nl Controleer de toestand van het metselwerk voor de installatie. Indien gewenst is het bij de levering inbegrepen bevestigingsmateriaal niet geschikt voor montage.

de Die Aufstellfläche der Duschkabine muss eben sein.

en The installation surface of the shower enclosure must be level.

fr La surface d'installation de la cabine de douche doit être plane.

nl Het montagevlak van de douchewand moet waterpas zijn.

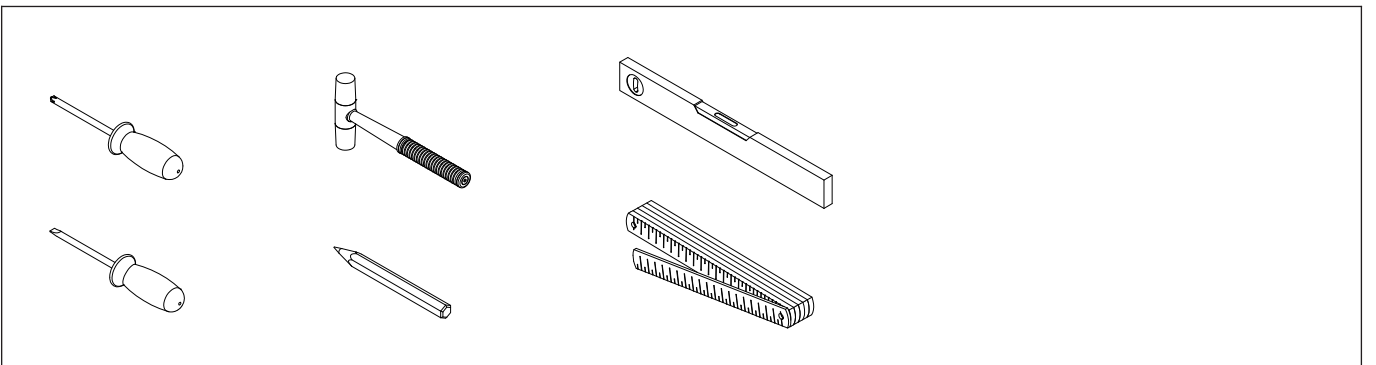
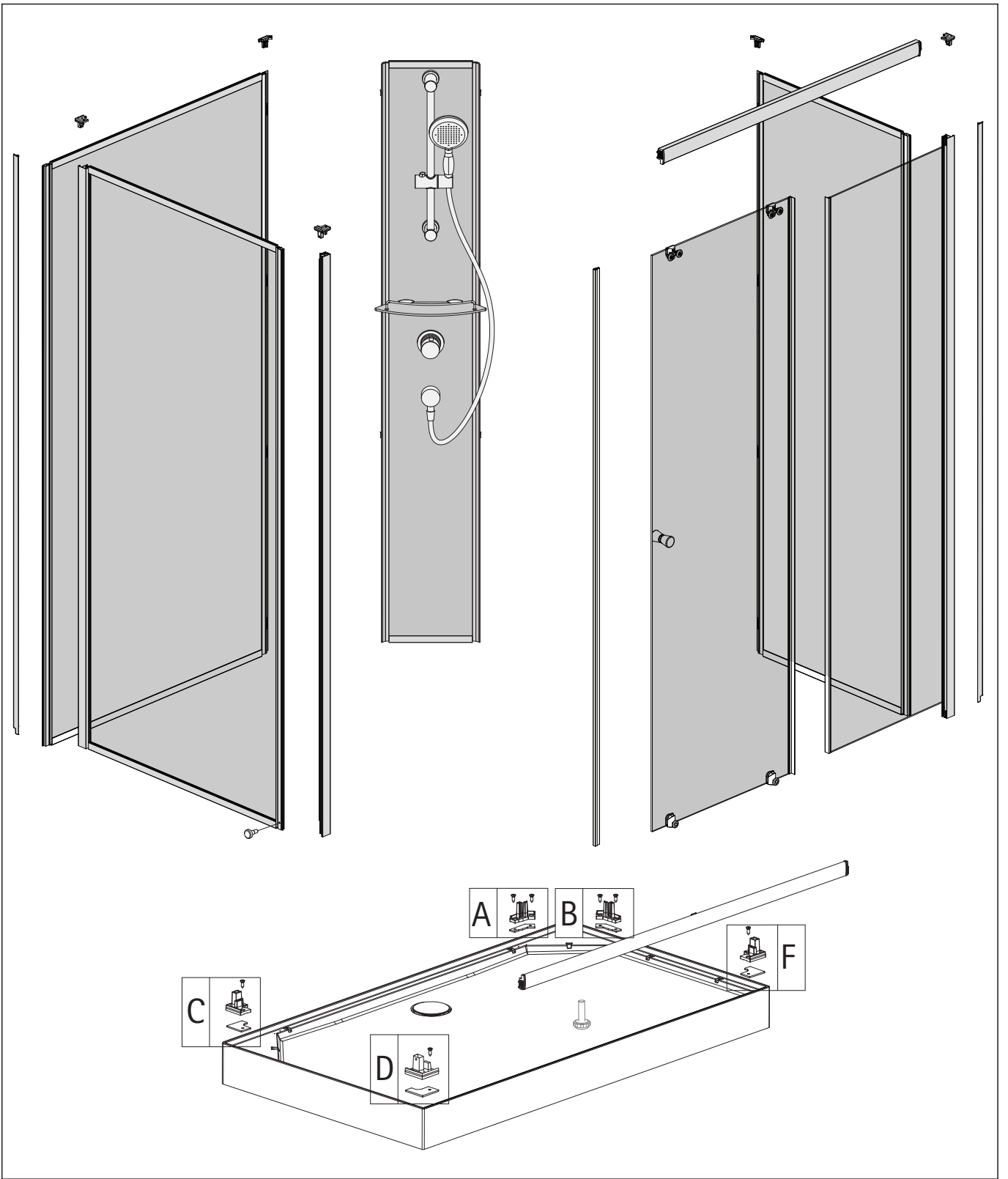

Teil 1 von 4 Teilen

colis 1 from 4 colis

colis 1 de 4 colis

colis 1 van 4 colis

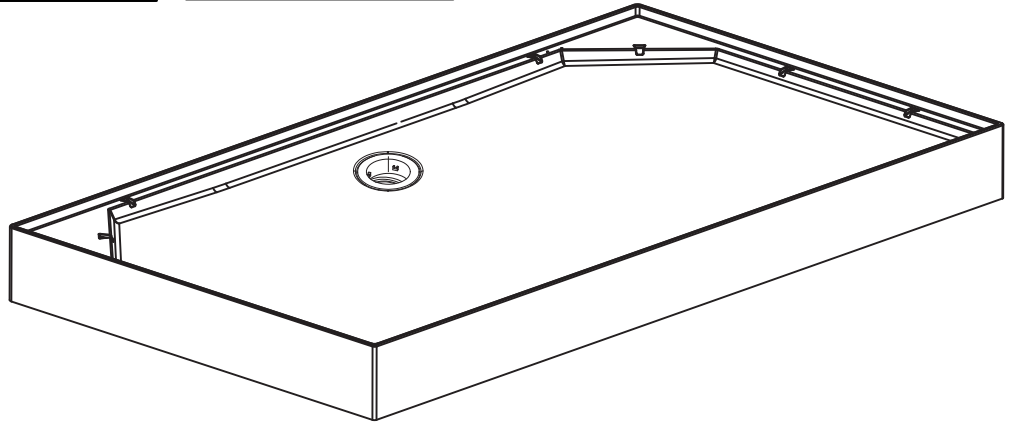
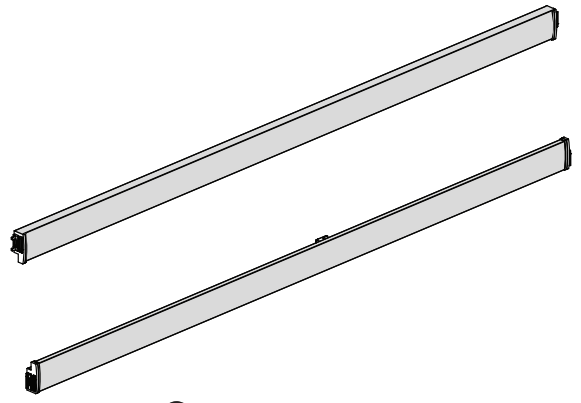
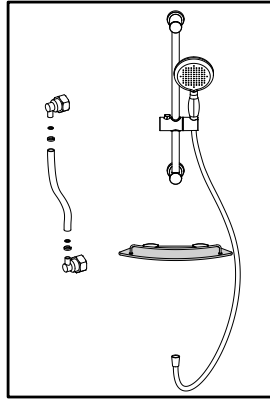
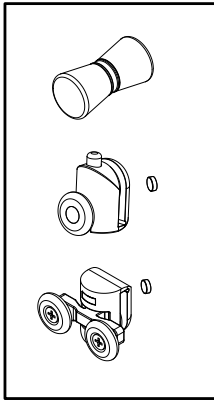
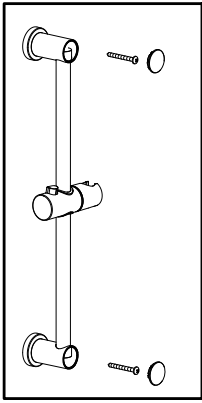

Teil 2 von 4 Teilen

colis 2 from 4 colis

colis 2 de 4 colis

colis 2 van 4 colis

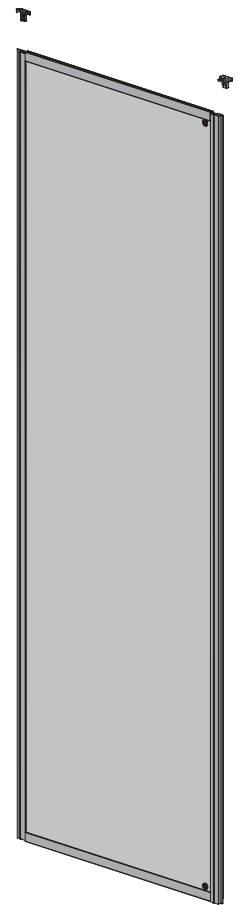
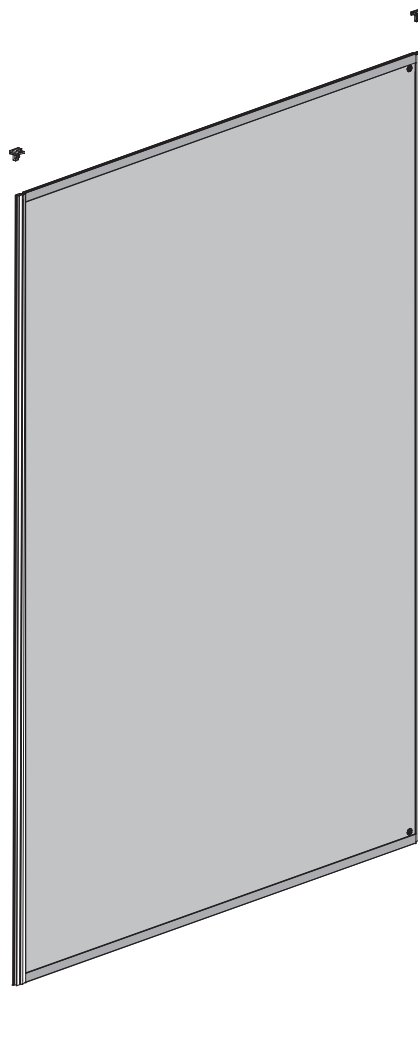
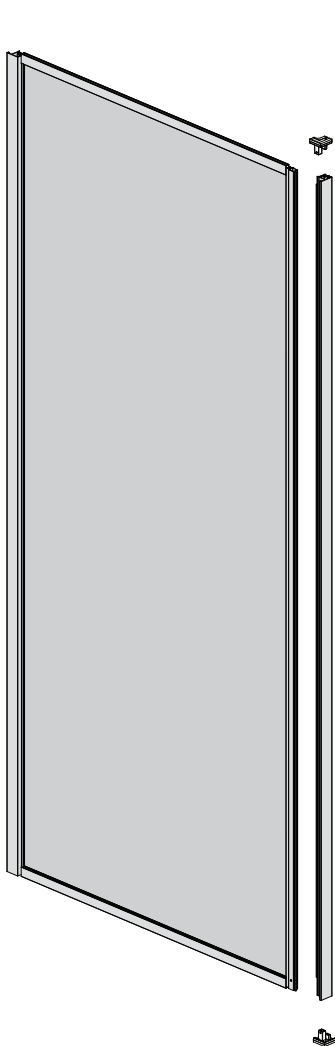

Teil 3 von 4 Teilen

colis 3 from 4 colis

colis 3 de 4 colis

colis 3 van 4 colis

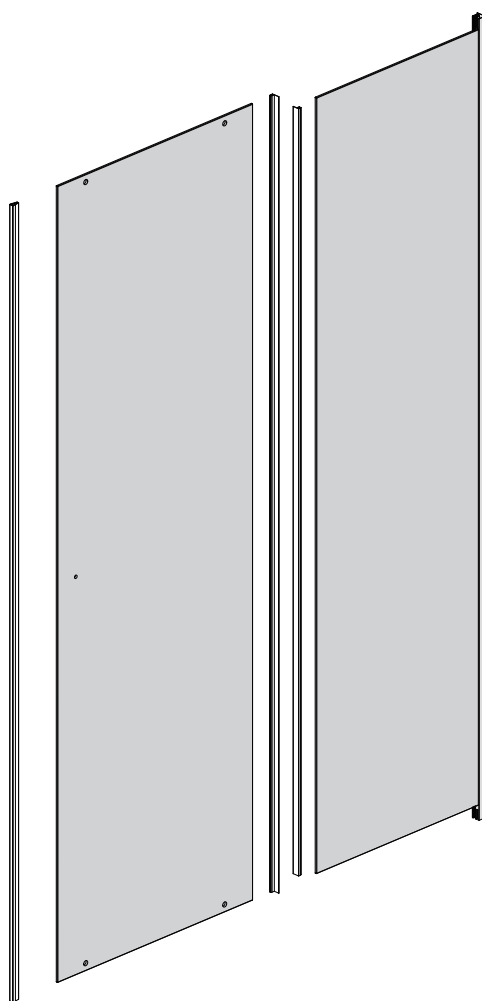

Teil 4 von 4 Teilen

colis 4 from 4 colis

colis 4 de 4 colis

colis 4 van 4 colis

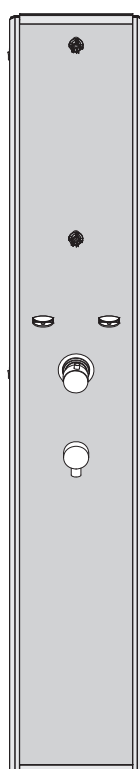

de Sehr geehrter Kunde!

Durch den Transport kann sich der Ablauf der Duschwanne gelöst haben.
Bitte ziehen Sie den Ablauf mit der Montagehilfe wieder fest.

en Dear customer

Through the transport, the drain of the shower tray may have come off.
Please retighten the drain using the assembly aid.

fr Cher(e) client(e),

Le système d'écoulement peut se détacher lors du transport. Merci de le remonter comme indiqué sur la notice de montage.

nl Geachte klant!

Door het transport kan het zijn dat het sifon losgekomen.
Zet het sifon zoals onder beschreven weer vast.

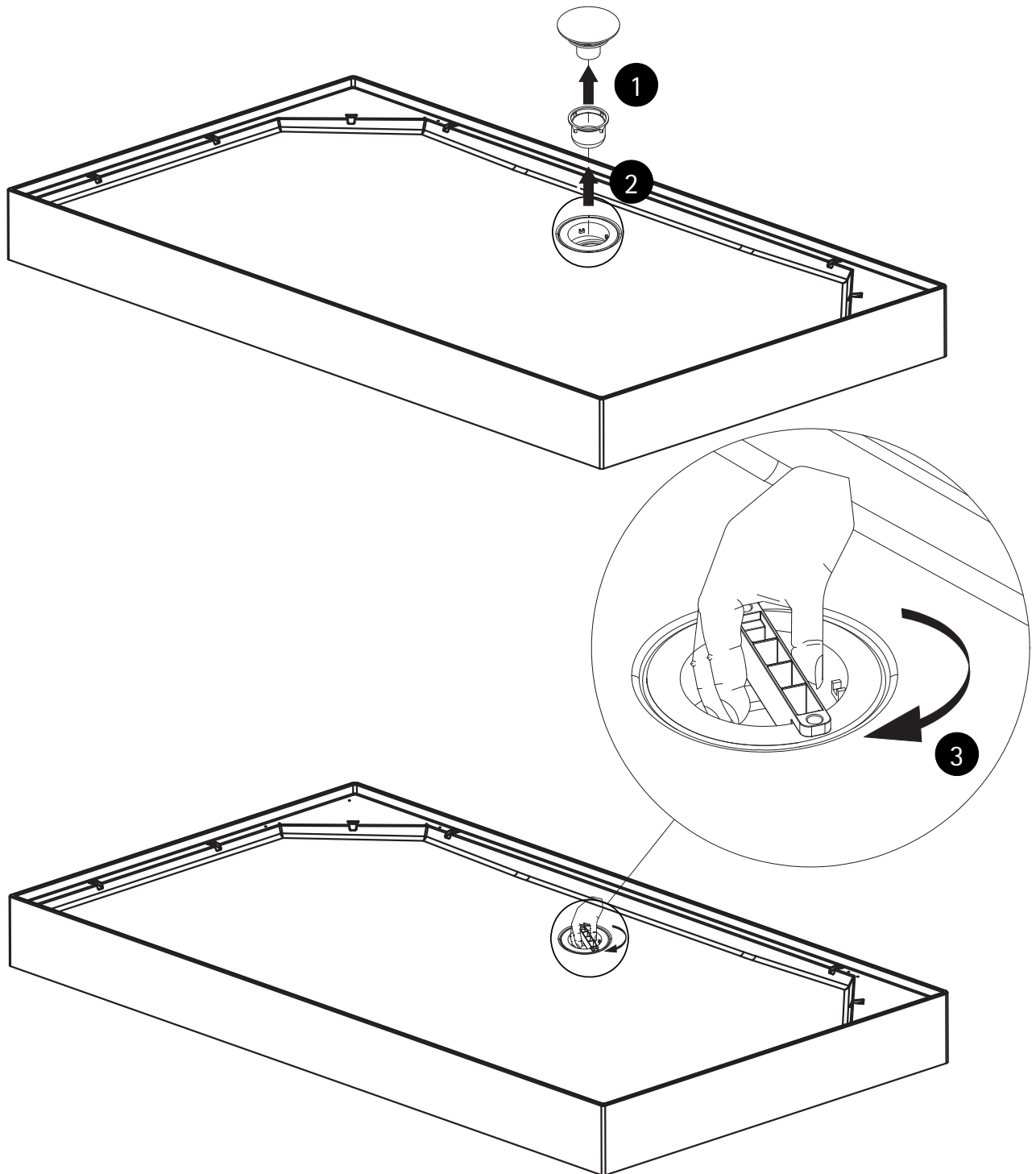
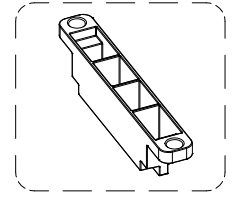



Montagesituation links / Assembly situation left /
Situation de montage à gauche / Montage situatie links

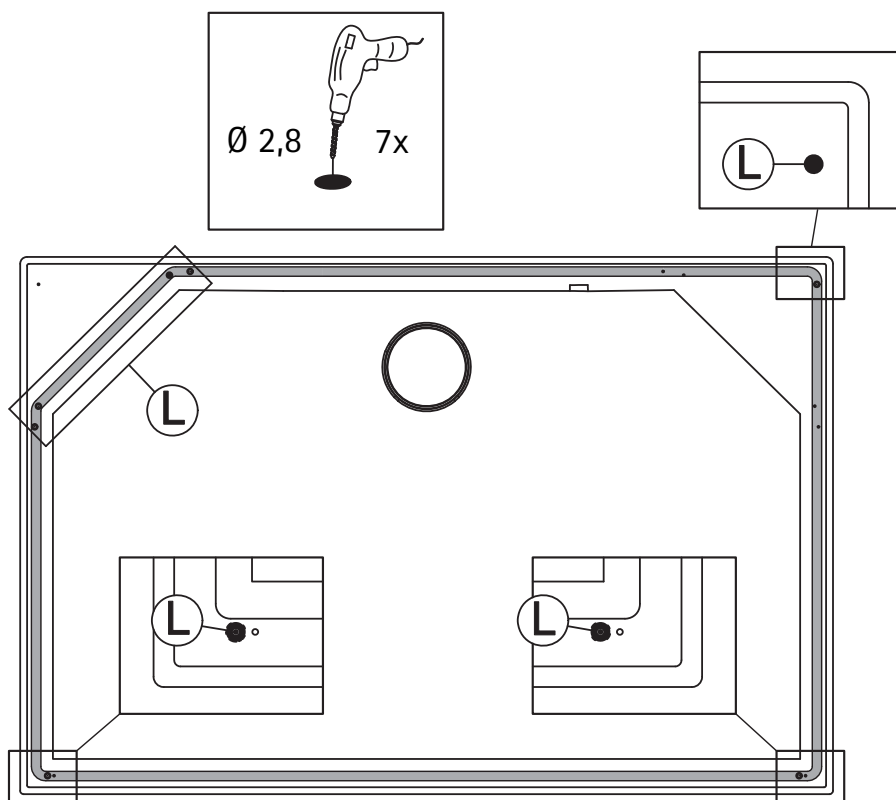
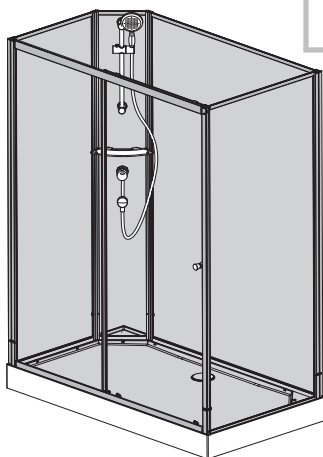

Montagesituation rechts / Assembly situation right /
Situation de montage à droite / Montage situatie rechts

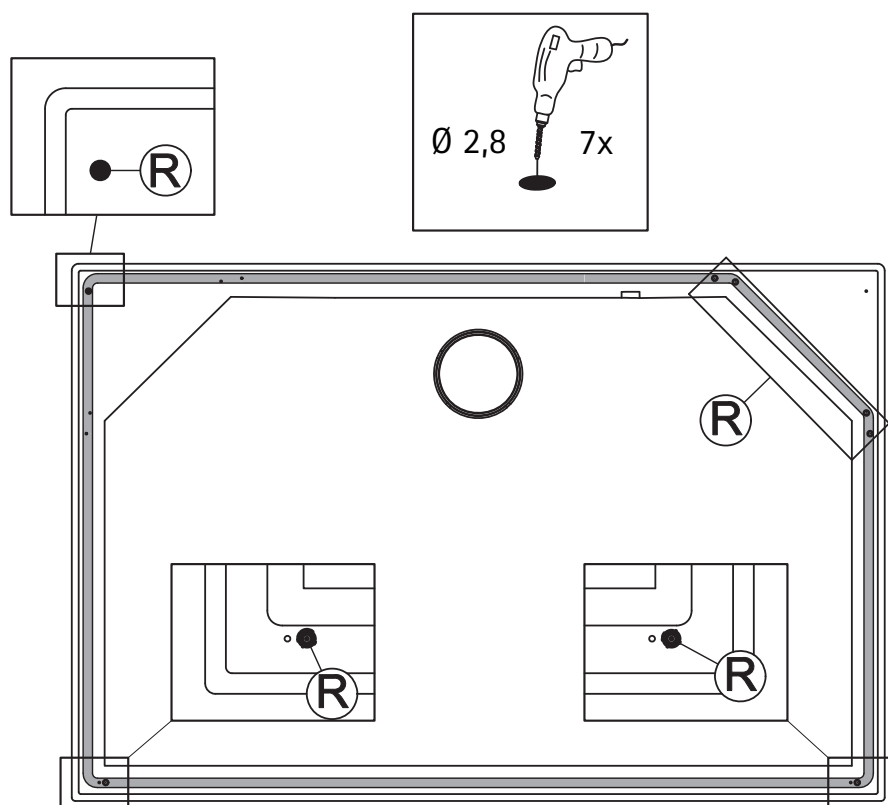
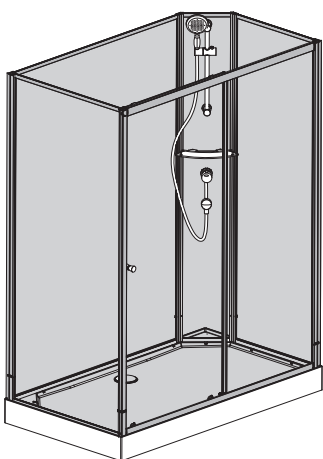



Montagesituation links / Assembly situation left /
 Situation de montage à gauche / Montage situatie links

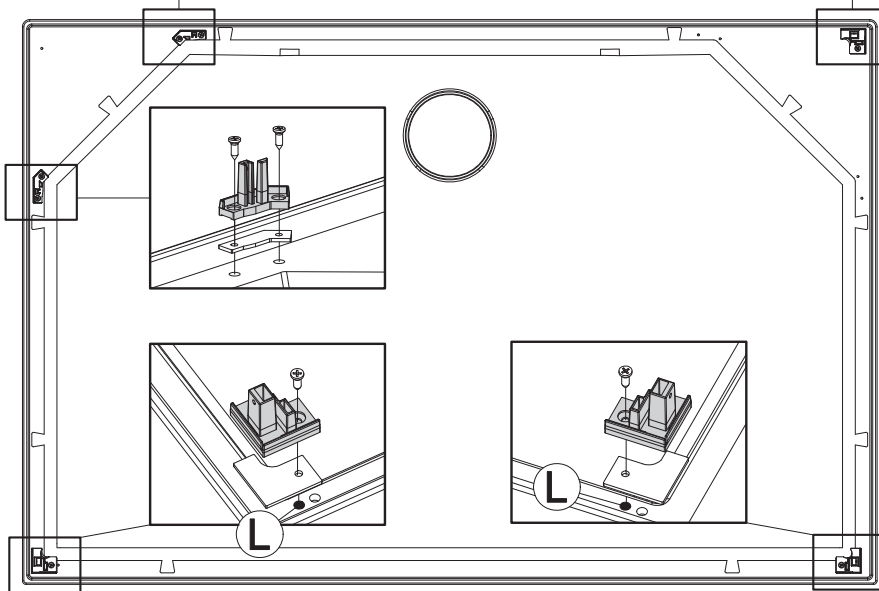
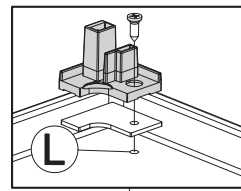
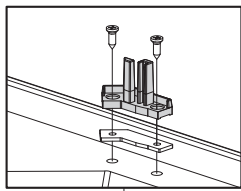
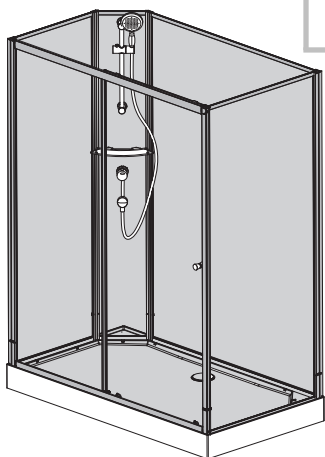

Montagesituation rechts / Assembly situation right /
 Situation de montage à droite / Montage situatie rechts

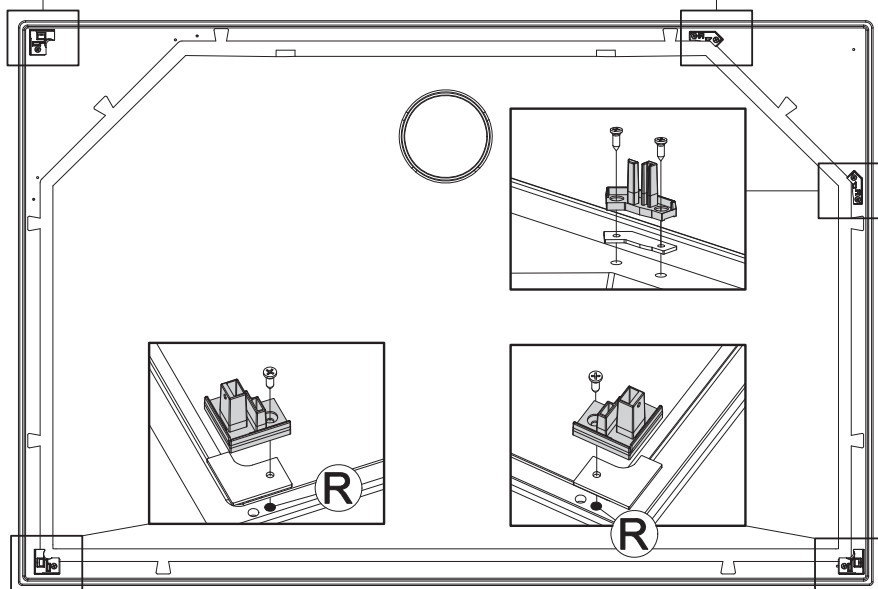
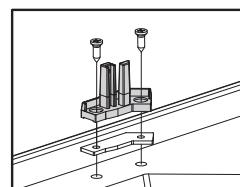
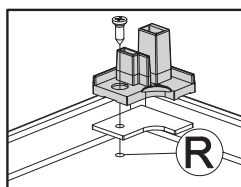
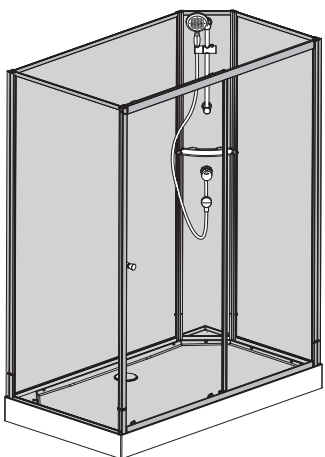

BENÖTIGTES WERKZEUG / TOOL NEEDED
OUTILLAGE NECESSAIRE / BENODIGD WERKTWIG

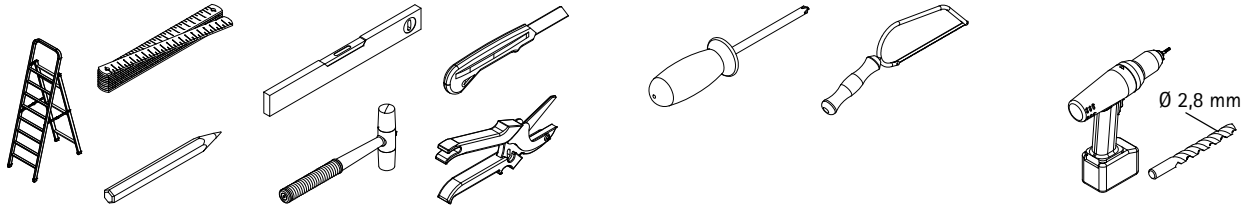

MONTAGE / ASSEMBLY / ASSEMBLAGE / ASSEMBLAGE

1

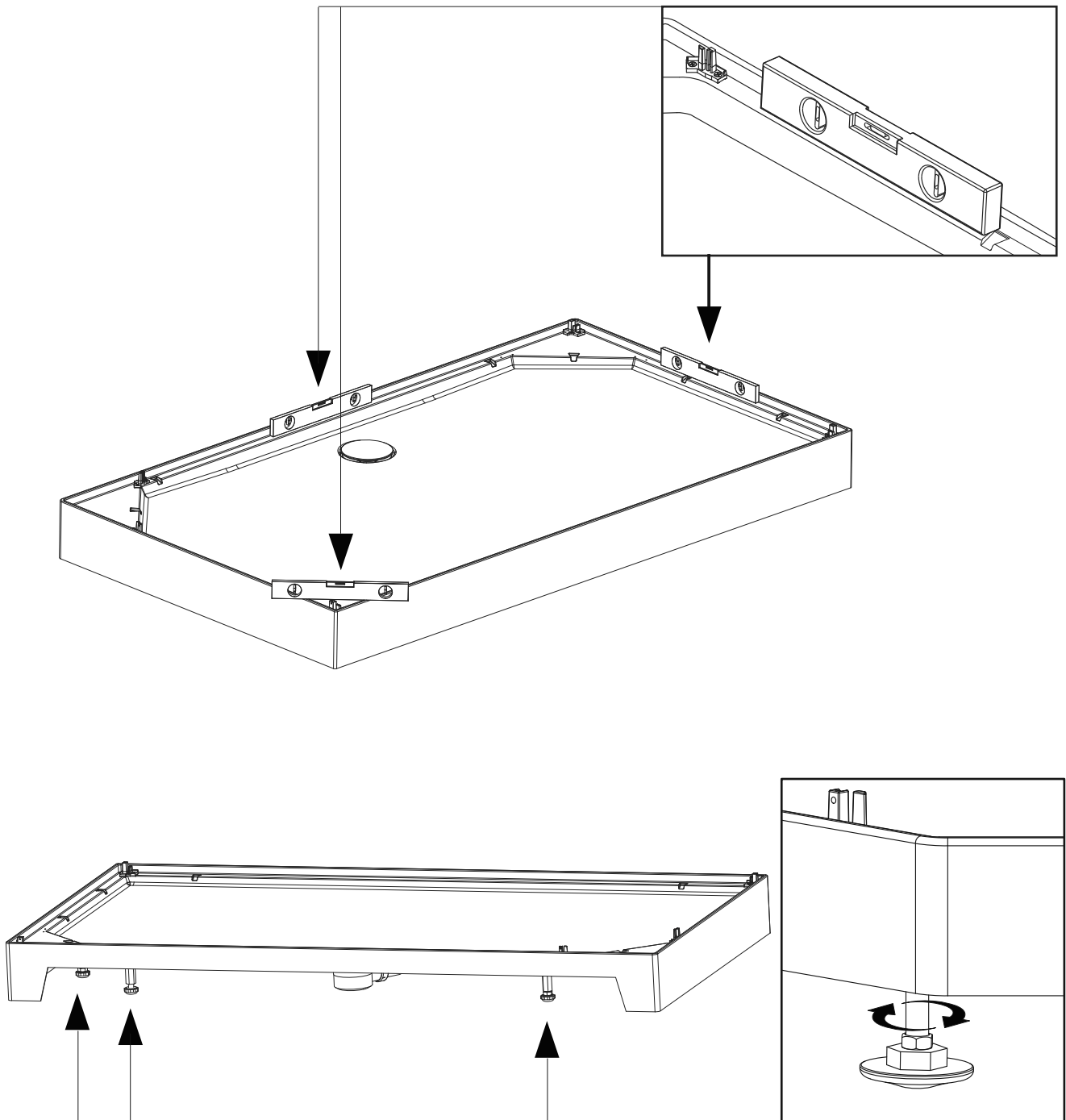

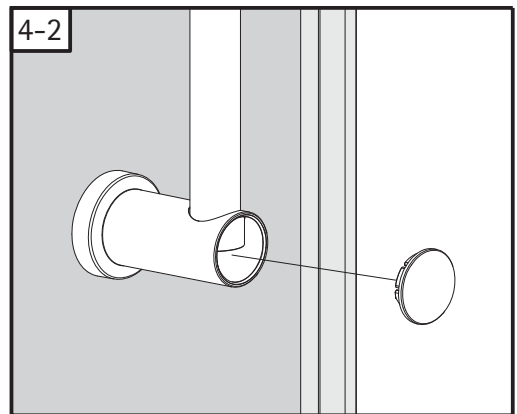
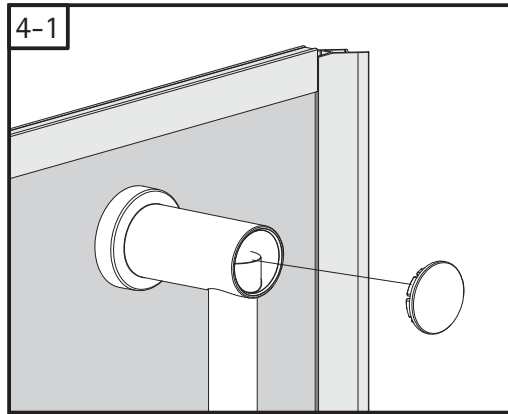
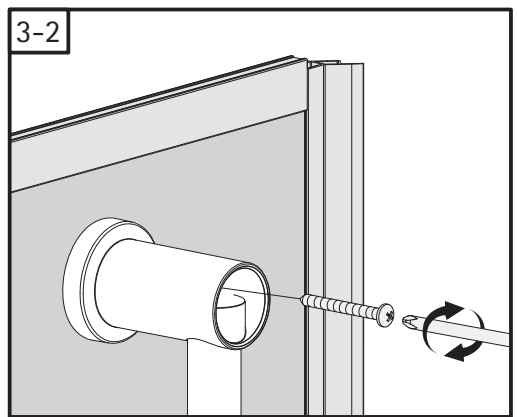
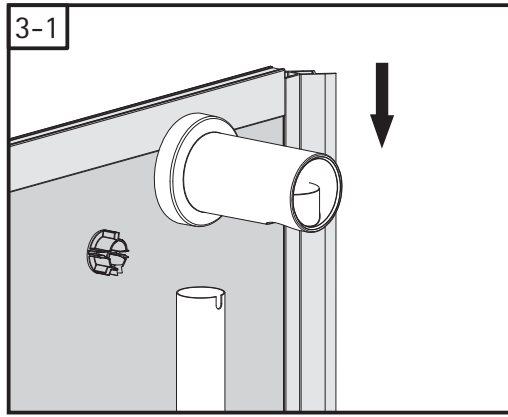
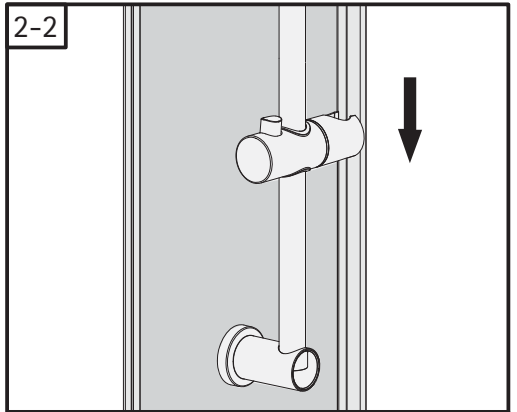
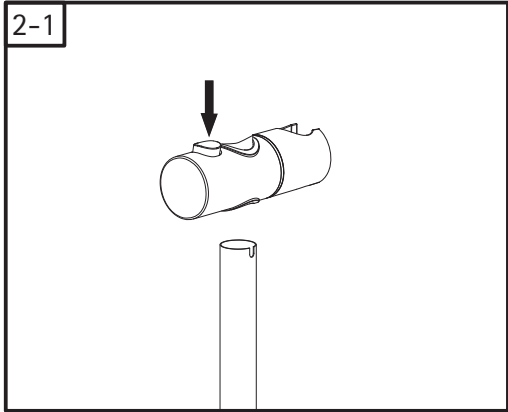
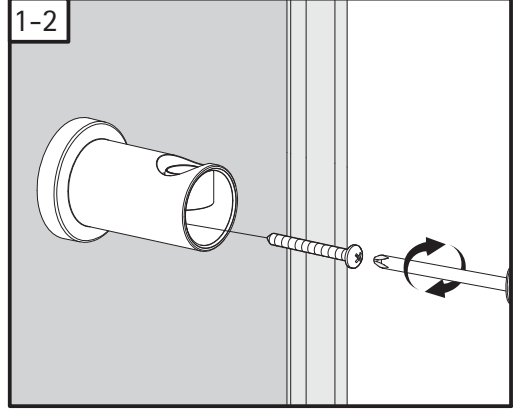
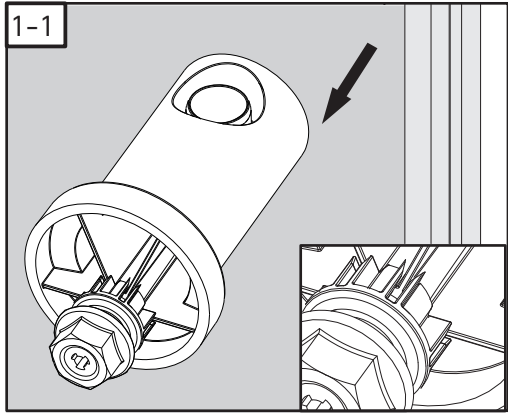
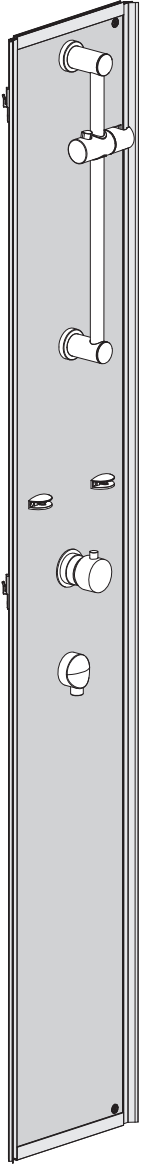

3

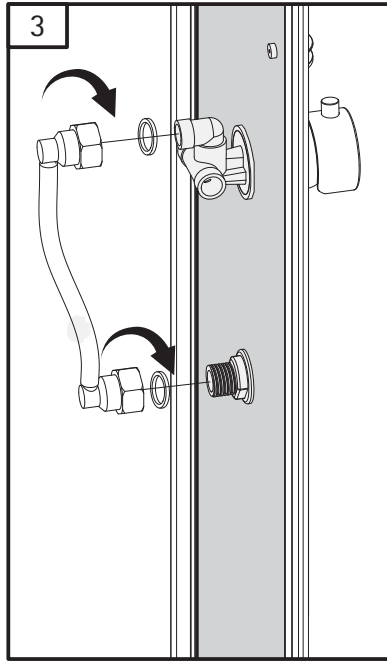
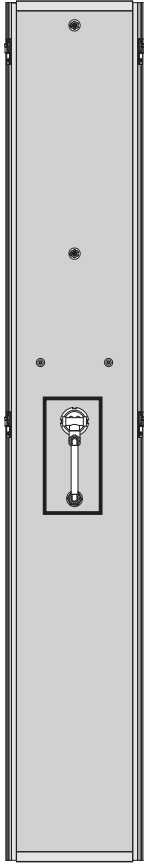

4

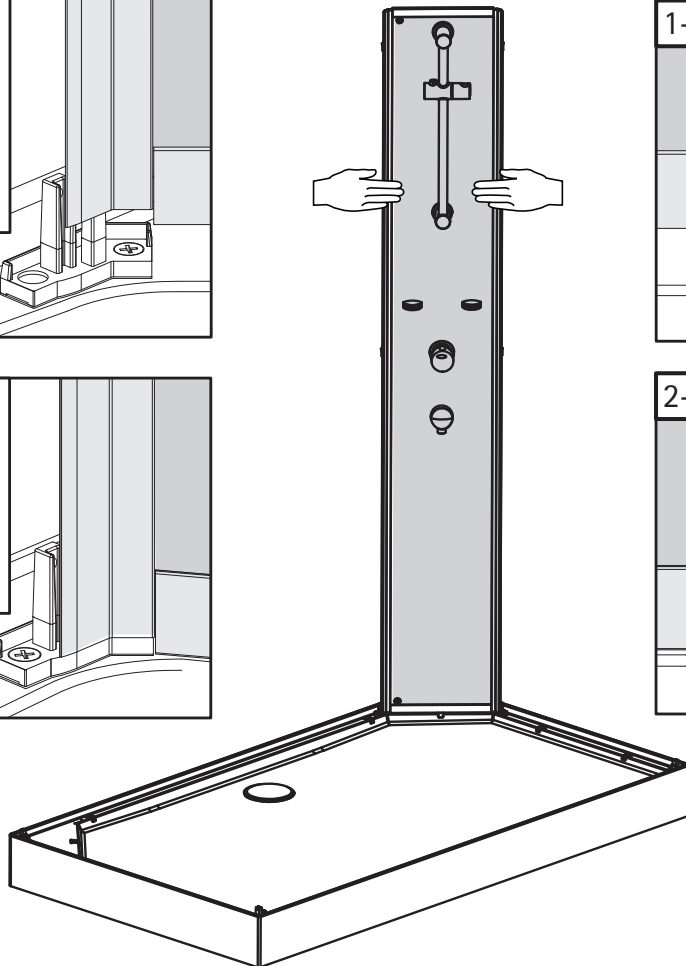
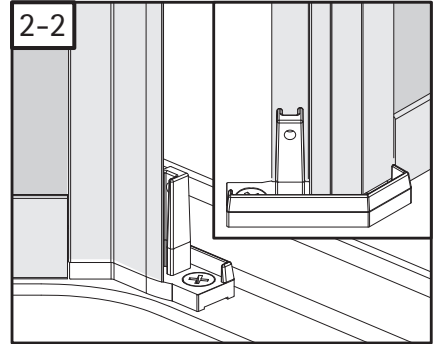
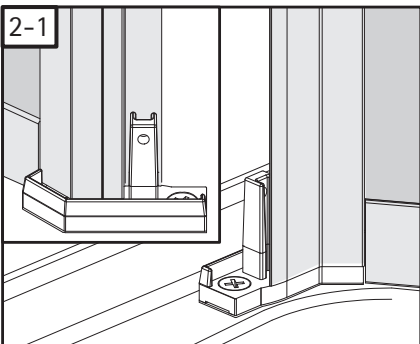
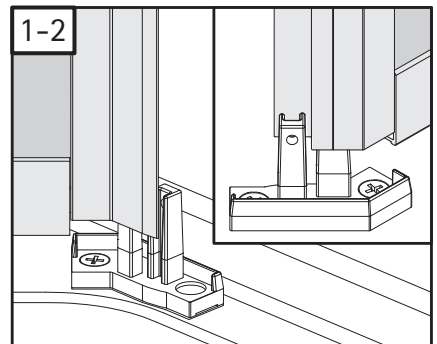
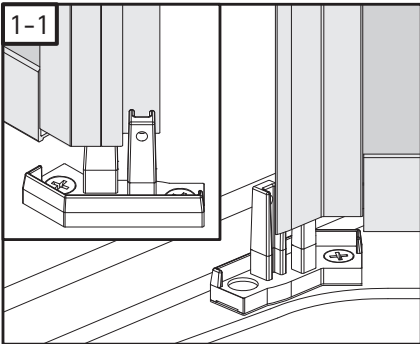

5

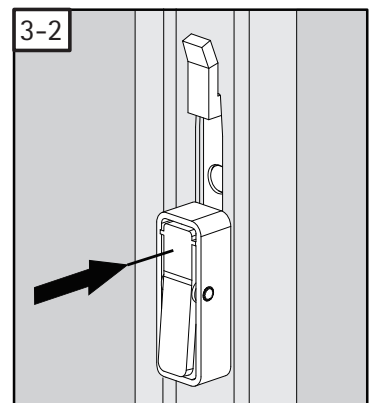
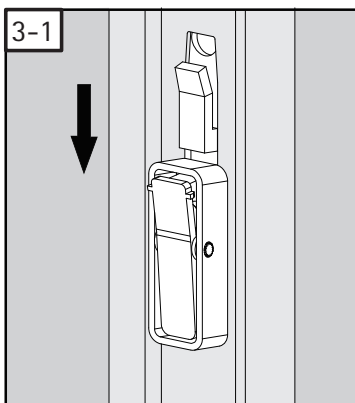
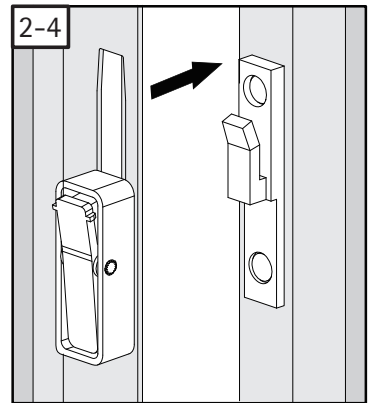
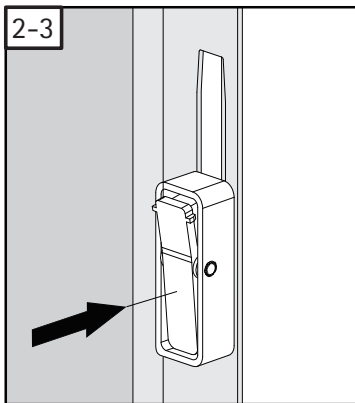
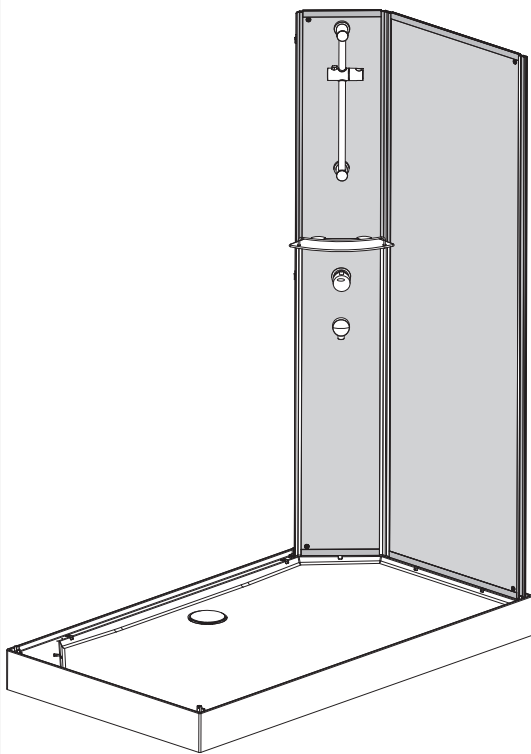
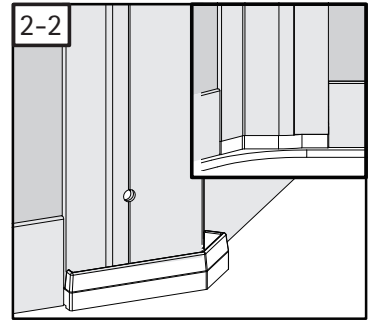
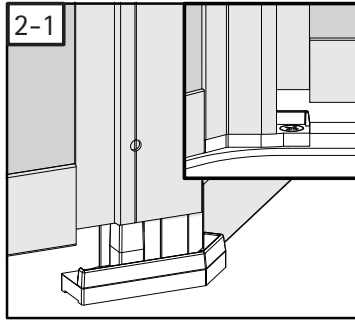
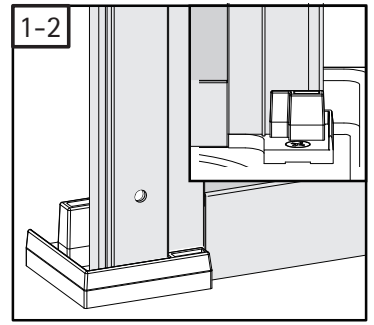
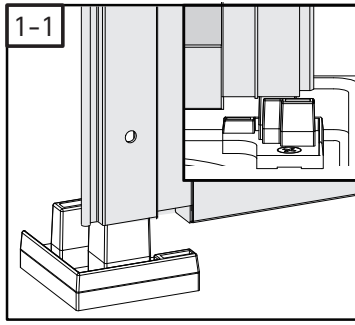
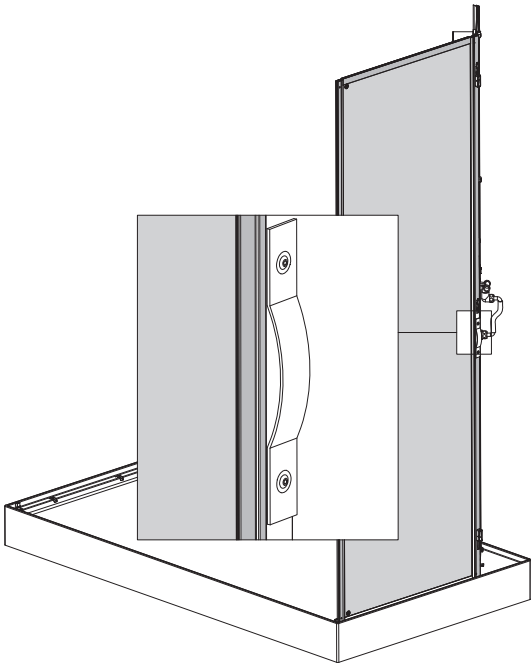

6

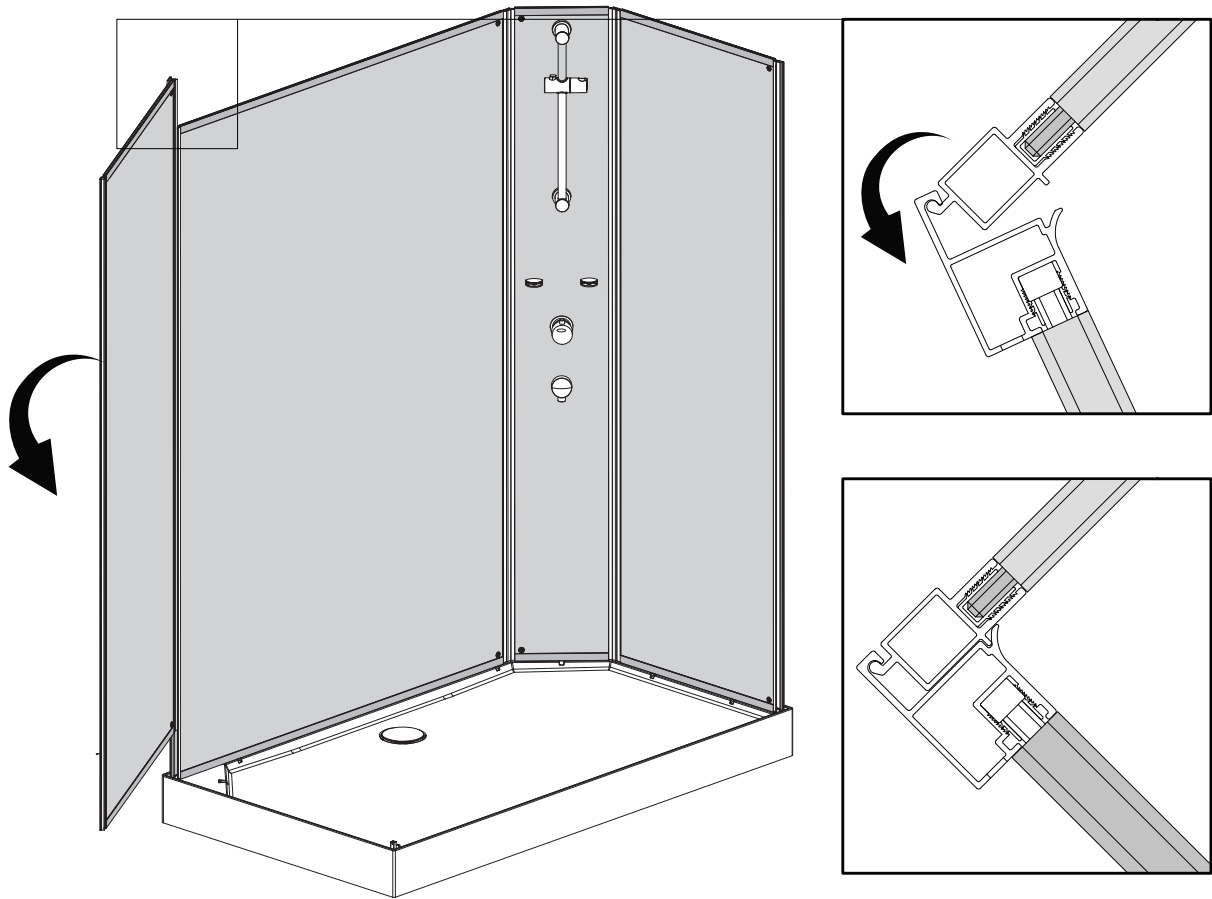

7

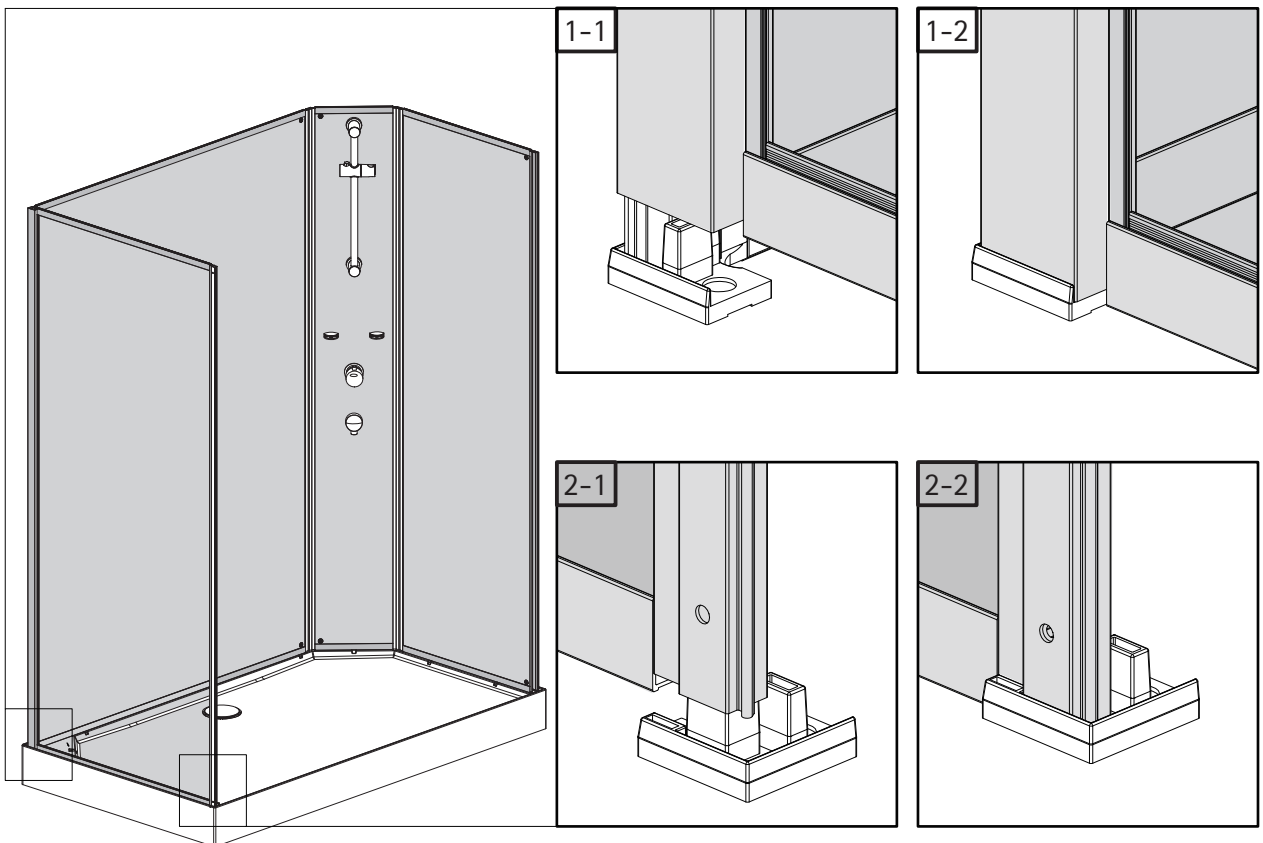

8

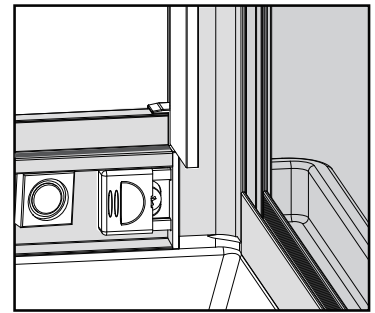
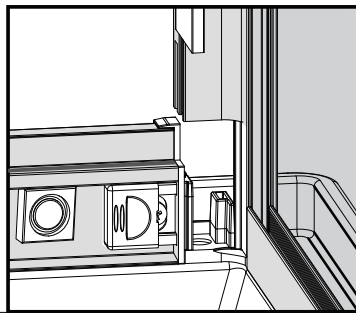
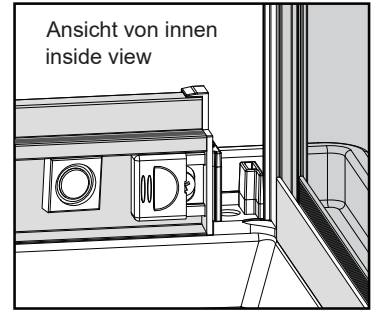
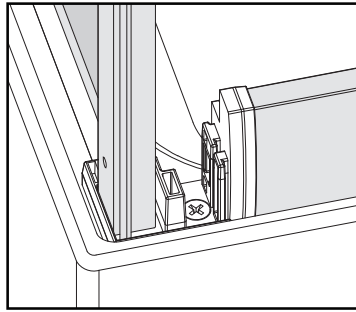
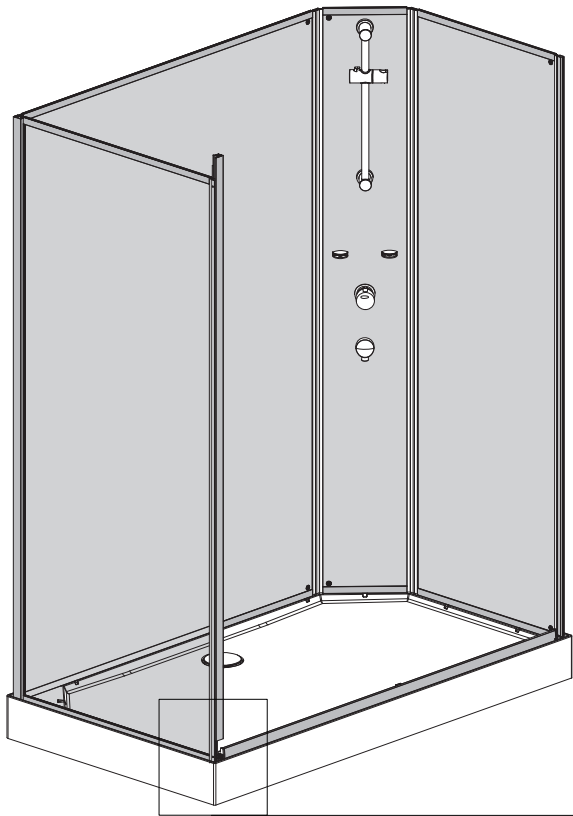

9

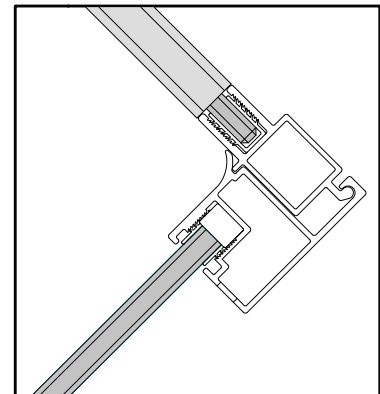
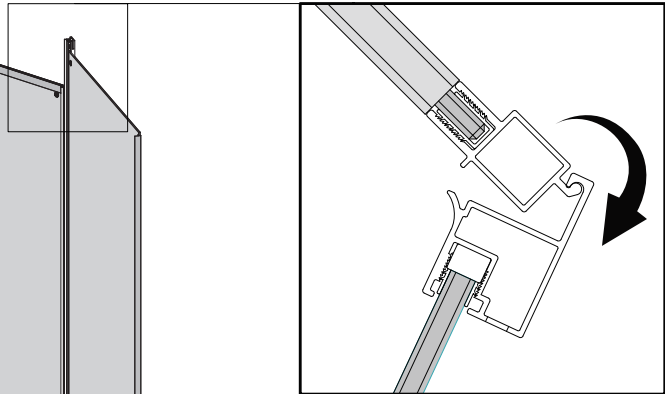
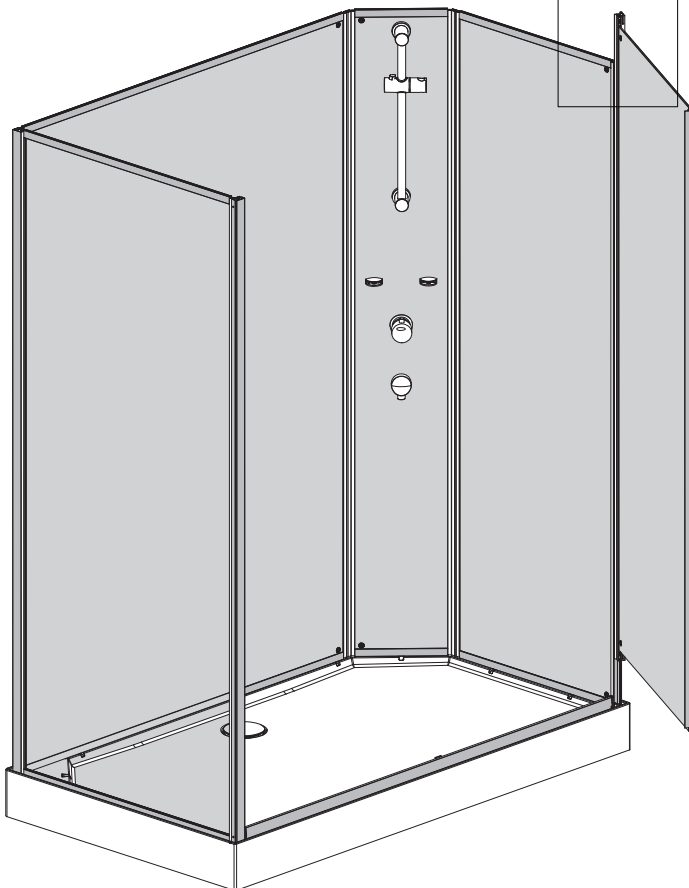

10

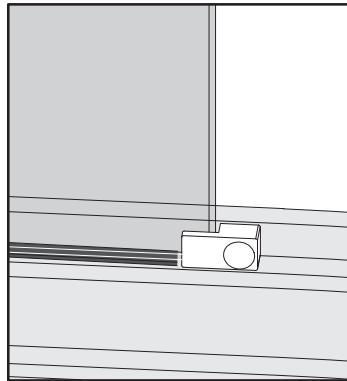
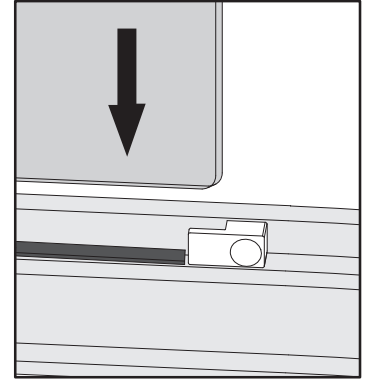
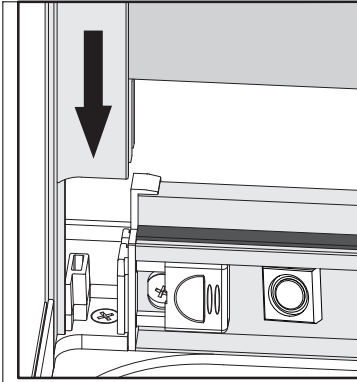
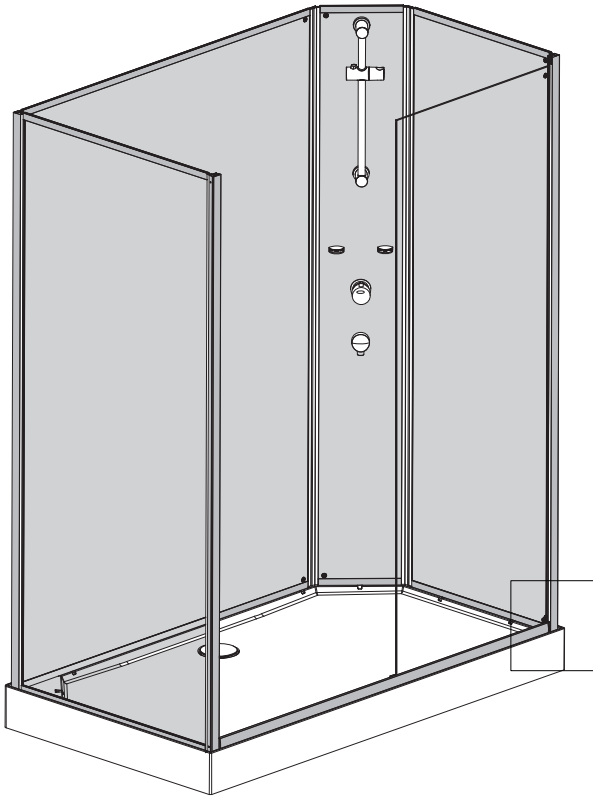

11

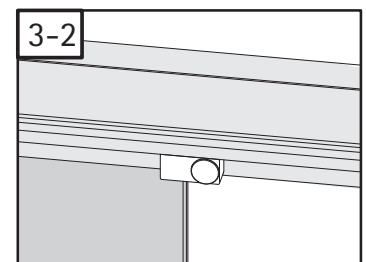
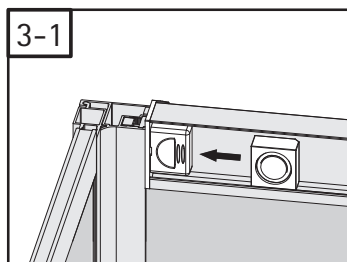
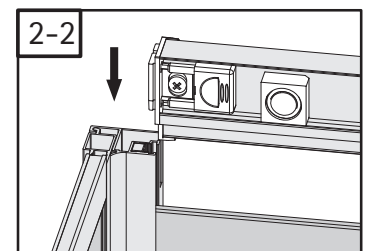
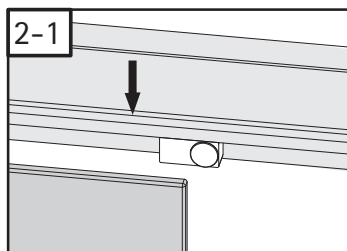
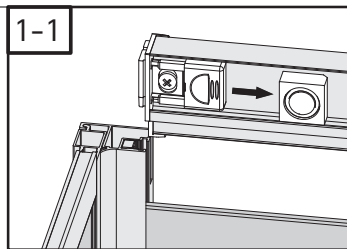
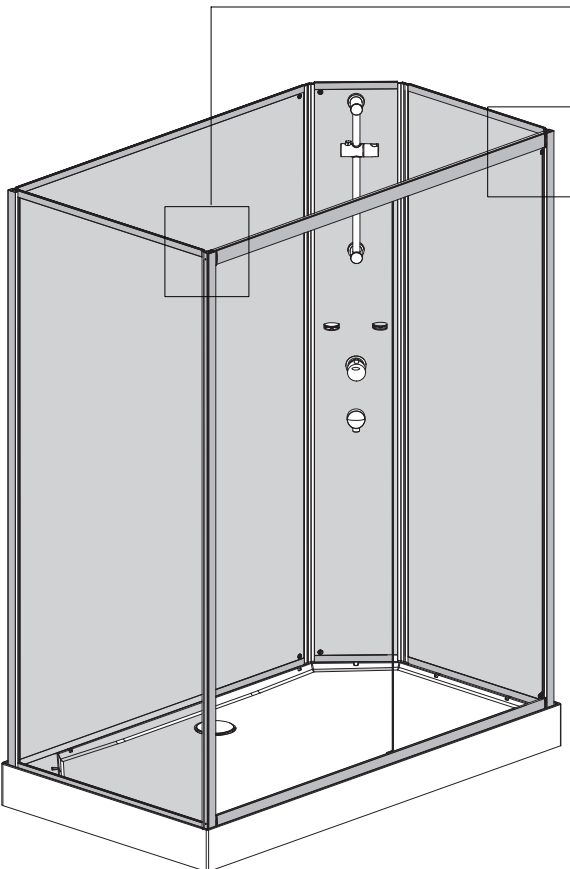

12

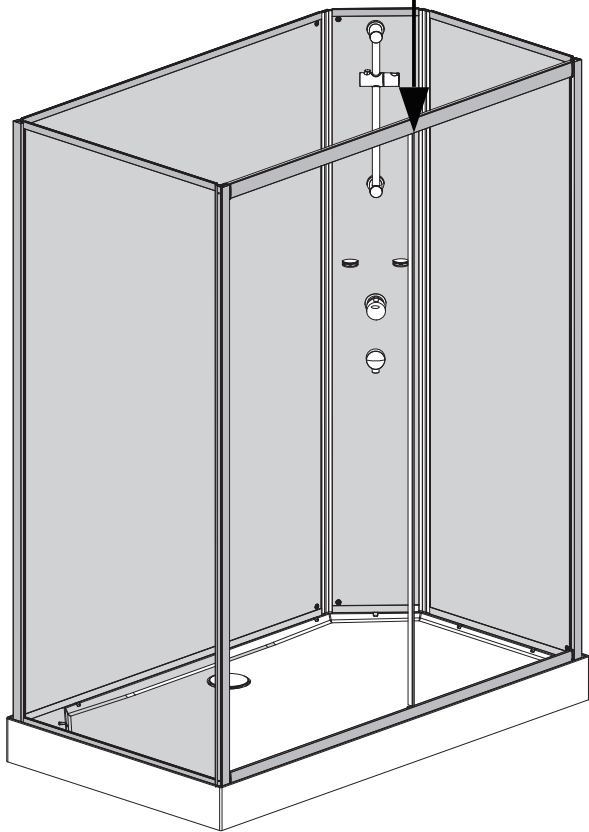

Ansicht von innen
inside view

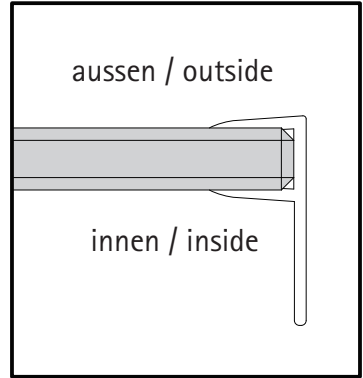
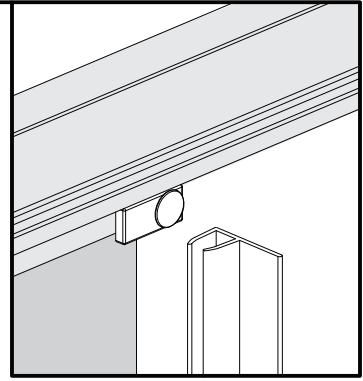

13

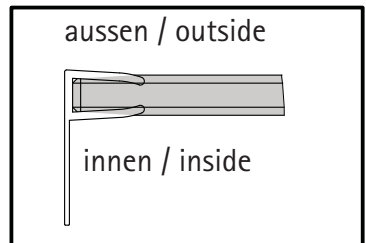
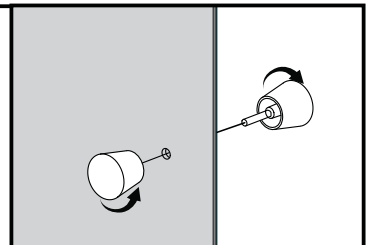
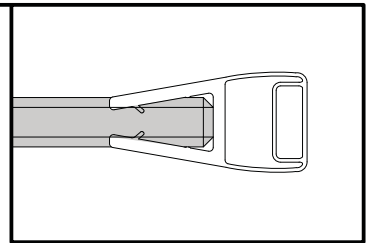
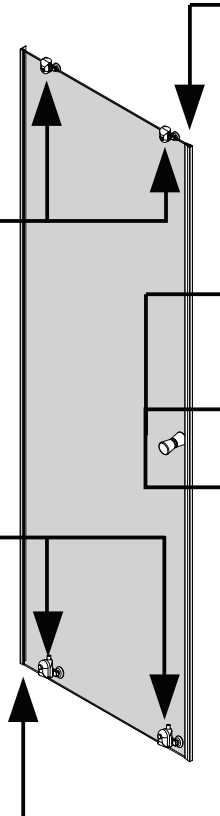
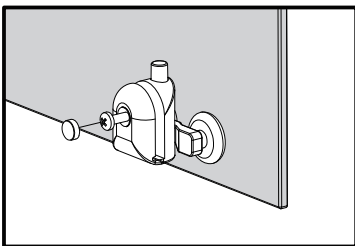
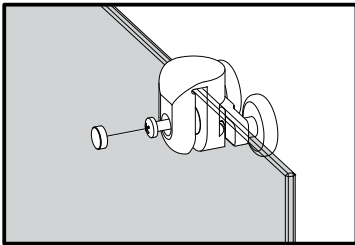

14

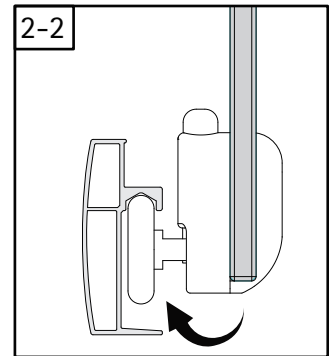
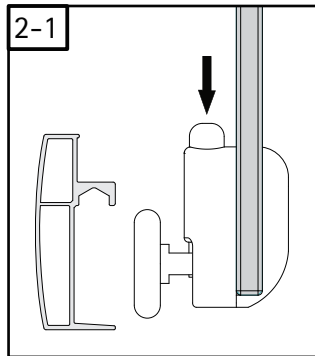
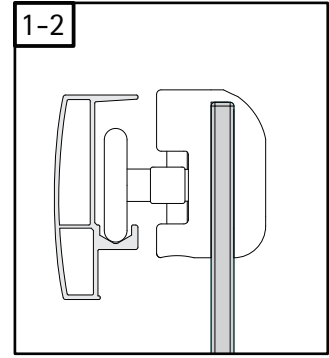
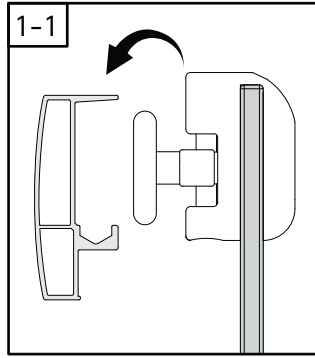
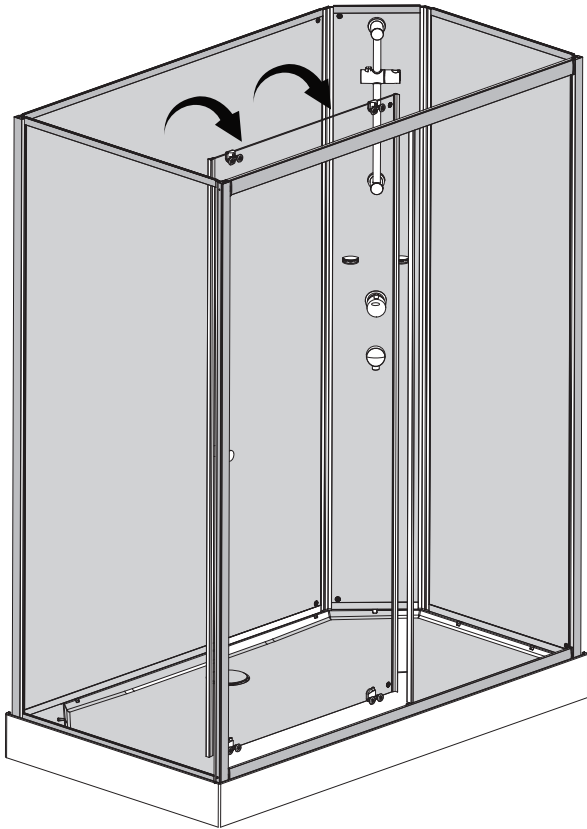

15

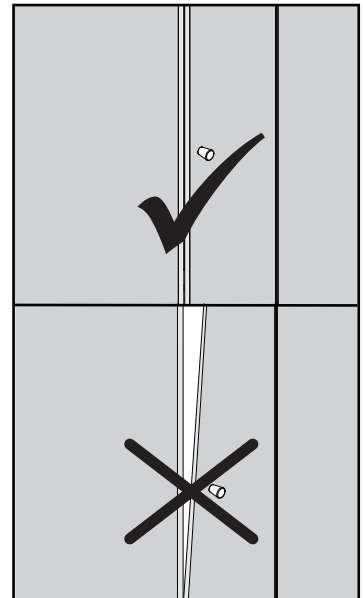
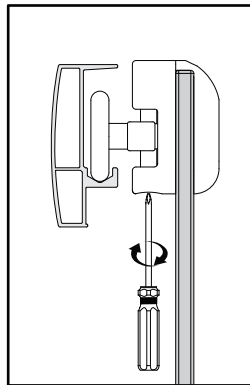
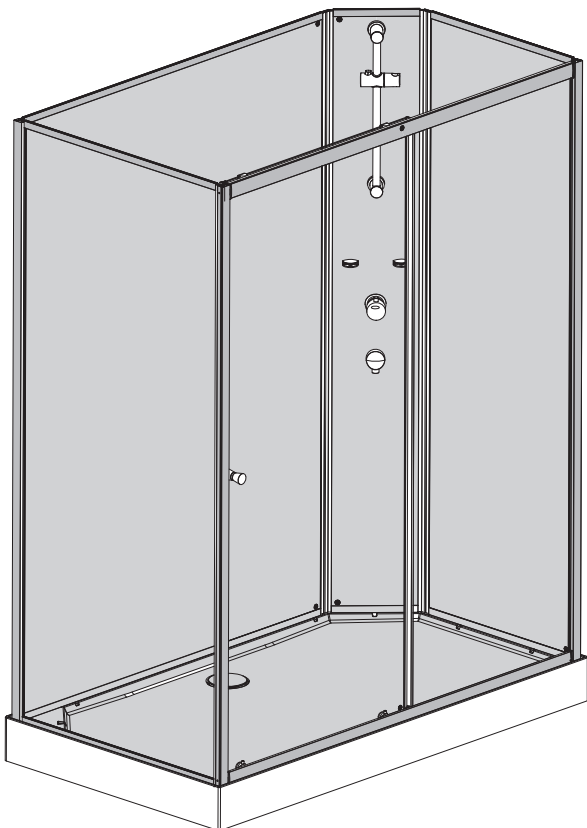

16

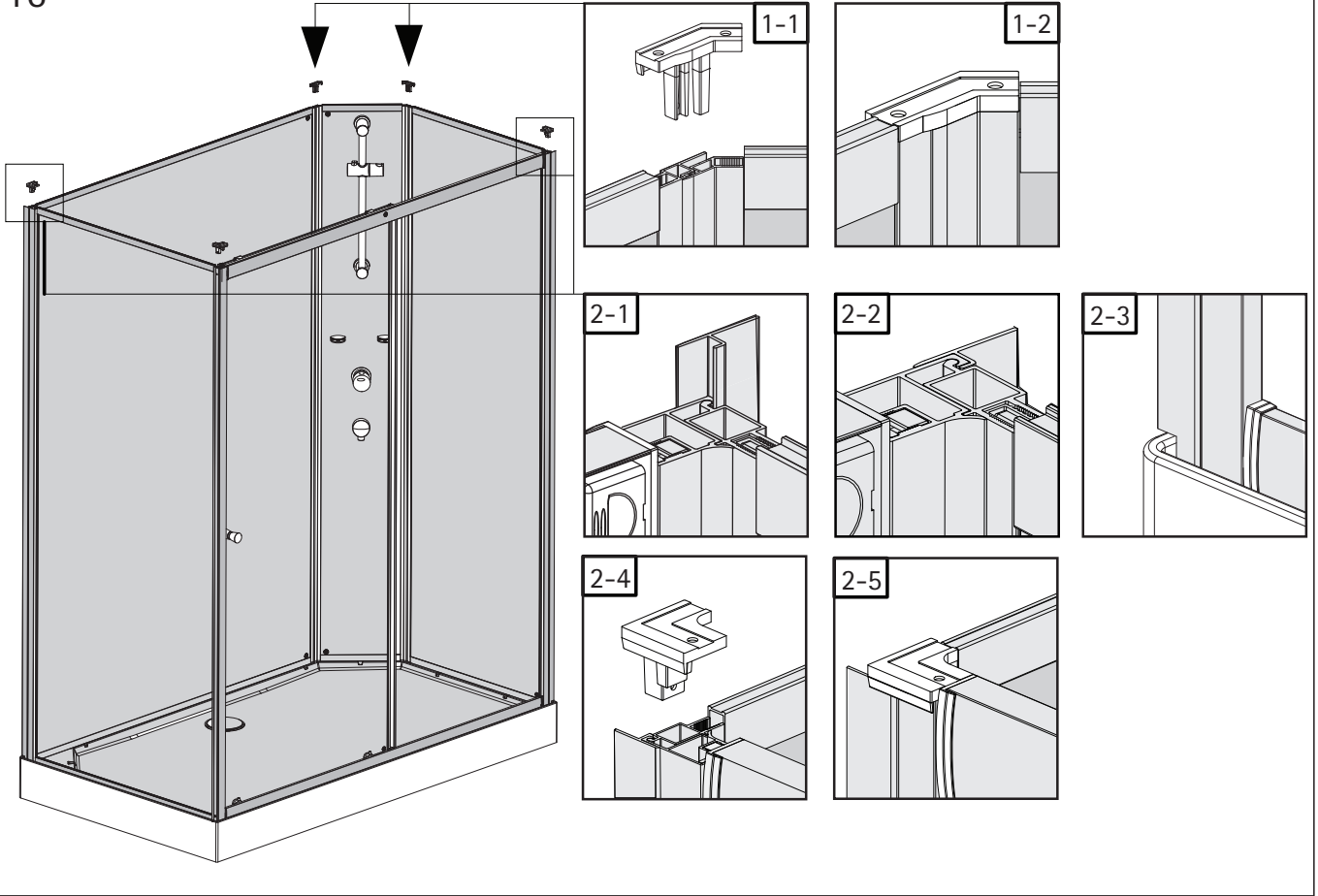

17

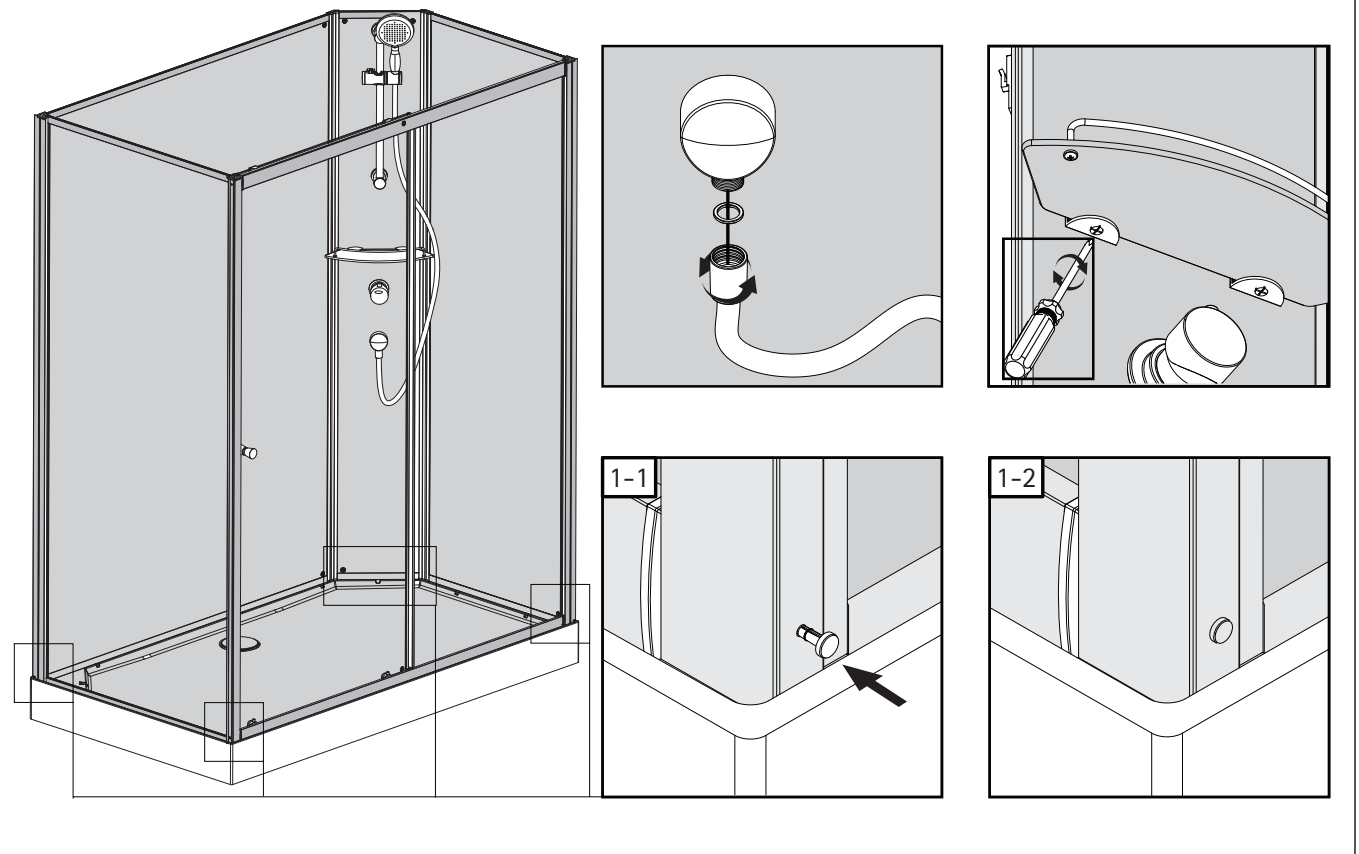

Notizen, notes, notities



7023-2

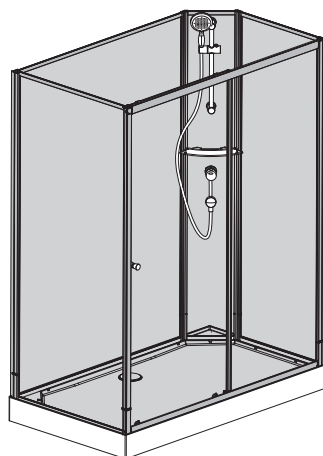
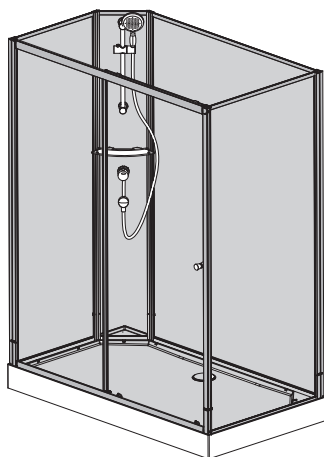

Technische Hilfe / technical help / l'aide technique / technologische ondersteuning
Ersatzteilbestellung / spare parts order
commande de pièces détachées / Bestelling van onderdelen:
Telefon 02631 / 8607-0



E-Mail: info@duschkabine.com



Dusch-Info
August-Horch-Straße 1
56566 Neuwied
Deutschland / Germany / Allemagne / Duitsland

